

S SERIES 1

4X8/5X10 TABLES

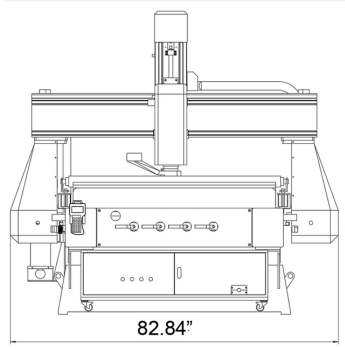

**4x8
TABLE**

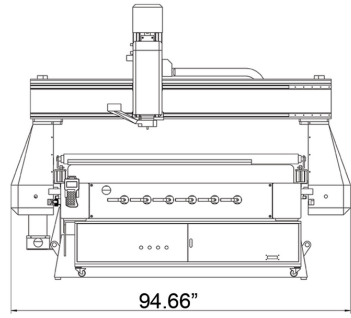
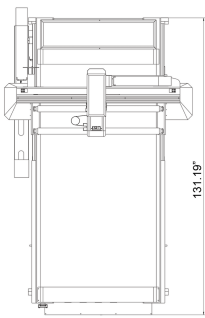

**5X10
TABLE**

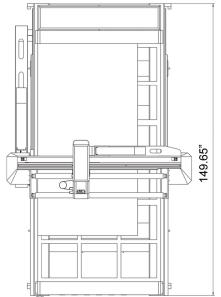

Machine Voltage	220V 1PH 3 Wire 60HZ 30 Amp
Working area	X Y axis: 4ft x 8ft, 5ft x 10ft, or Custom Z axis: 8inch or 11.8inch
Vacuum Table	Bakelite Vacuum Table Surface Multi-Zone Vac Table T-Slot Clamping Table
Machine Structure	Fully Welded Steel Frames
Spindle	Air cooled spindle 4.5KW / 6.1 HP
Tool Cooling	Oil-Mist Cooling System
Inverter	220V Single Phase 4.5KW
Motion Supports	Linear guide XZ Linear guide Y Ball screw Z Rack 1.25M Taiwan J&T /Rack has dustcover
Motor and Drive	Micro Stepping
Control System	Pendant Control System for easy controls
Pneumatic Rollers	Automatic Rollers with 600lbs of pressure
Tool Sensor	Touch probe for Z axis zero
Lubrications System	Automatic Lubrication system with pump
Vacuum Rotary Vane Pumps	30 Amp 220V Single Phase
Machine Weight	2300 (4x8) -2600 (5x10) lbs

Dust Collectors

Phantom CNC Systems offers several levels of dust collectors to meet the needs of your business. All of our dust collectors have pleated filters.



Vacuum Pumps

The 2.2KW Rotary Vane Pumps are big power in small packages. One pump is more than enough to handle the Shadow machine. These are powered on a 30 amp 220v single phase line. No 3 Phase is needed!



CALL NOW : (252) 229-3896

SALES@PHANTOMCNCSYSTEMS.COM

WWW.PHANTOMCNCSYSTEMS.COM