

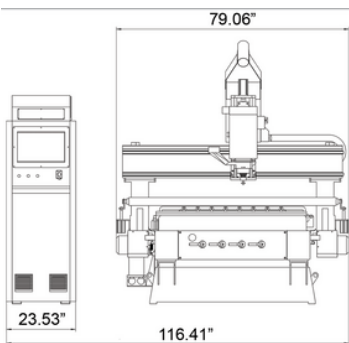

# REAPER

4X8/5X10 TABLES



**4x8  
TABLE**

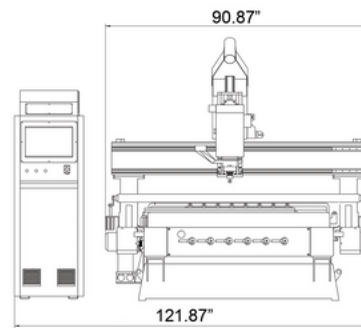
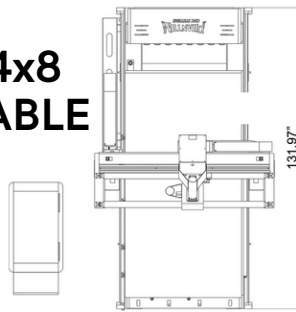

**5X10  
TABLE**

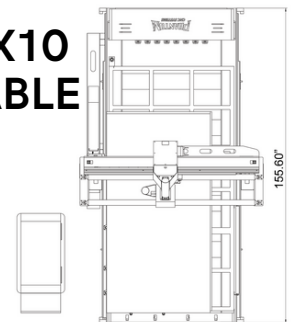

REAPER	
Machine Voltage	220V IPH 3 Wire 60HZ 50 Amp
Working Area	X Y axis: 4 ft x 8 ft, 5 ft x 10 ft, or custom Z axis: 11.8 in
Vacuum Table	Bakelite Vacuum Table Surface Multi-Zone Vac Table T-Slot Clamping Table
Reference Pins	Pneumatic Piston Reference Pins
Machine Structure	Fully Welded Steel Frames
Spindle	Air cooled spindle 16.1 HP VFD Driven. HQD, HSD, & Water Cooled available. 20,000 RPM
Tool Cooling	Oil-Mist & Air Cooling System
Inverter	220V Single Phase 11KW
Motion Supports	Linear Guide: XY with rack and pinon drive Linear Guide Z with rack and pinon drive Ball Screw: on Z axis with hardened ball screw Rack 1.25M Taiwan J&T / Rack has dust cover
Motor & Drive	Delta 750 Watt Servo Motor & Drives: 750, 850, & 1000 watts
Control System	Pendant Control System for easy control
Auto Tool Changer (ATC)	Pneumatic 8 tool changer - ISO 130
Pneumatic Rollers	Automatic Rollers with 600lbs of pressure
Tool Sensor	Touch probe for Z axis zero of current tool and G54 Setting Touch probe for Tool Setting
Lubrication System	Auto lubrication sysem for rack and pinons & ball screw
Machine Weight	4ft x 8ft: 3000lbs, 5ft x 10 ft: 3200lbs

## Dust Collectors

Phantom CNC Systems offers several levels of dust collectors to meet the needs of your business. All of our dust collectors have pleated filters.



## Vacuum Pumps

The 7.5KW Rotary Vane Pumps are big power in small packages. One pump is usually enough to handle the Reaper machine. These are powered on a 50 amp 220v single phase line. VFD included.

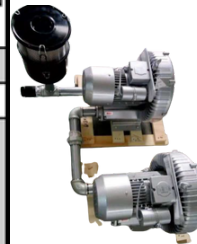

the  
**EVOLUTION**  
OF CNC

CALL NOW : (252) 229-3896

SALES@PHANTOMCNCSYSTEMS.COM

WWW.PHANTOMCNCSYSTEMS.COM