

# REAPER

## 4X8 / 5X10

### Machine Specifications

Machine Voltage	Working Area	Vacuum Table	Machine Structure
220V Single Phase 3 wire 60HZ 50Amp	X Y Axis: 4' x 8'  5' x 10'  Z Axis: 11.8"	Bakelite Vacuum Table Surface  Multi-Zone Vacuum Table  T-Slot Clamping Table	Welded Frame
Spindle	Tool Cooling	Motor & Drive	Control System
Air Cooled Spindle 16.1 hp (Options Available) 8,000 - 24,000 RPM	Oil Mist & Air Cooling System	Delta 750 watt Servo Motor & Drives	NK-280B
Auto Tool Changer	Pneumatic Rollers	Tool Sensor	Lubrication System
Pneumatic 8 Tool Changer with ISO30	Automatic Roller with 600lbs of pressure at each roller	Touch probe for tool length and Z axis work coordinate	Auto lubrication system for rack and pinions & ball screw
Machine Weight	Motion Supports		
4' x 8' 3,000 lbs  5' x 10' 3,200 lbs	Linear Guide: XY with rack & pinon drive.  Linear Guide: Z with rack & pinon drive.  Ball Screw: on Z axis with hardened ball screw.  Rack 1.25M Taiwan J&T / Rack has dust cover.		

### Machine Dimensions

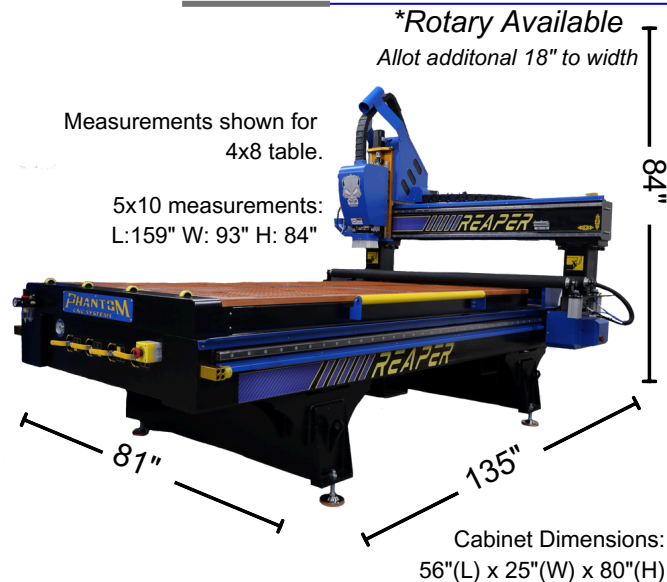

### Shipping Dimensions

These dimensions are the overall dimensions of the equipment shrink wrapped.

**135"(L) x 81"(W) x 84"(H) / 159"(L) x 93"(W) x 84"(H)**  
 Shipping cost vary on address and current carrier rates. Please contact for shipping quotes. Forklifts with 6ft forks are required. Cabinet not included in dimensions.

### Vacuum Pumps

Phantom CNC Systems offers vacuum pumps in 2.2kw, 5.5kw, and 7.5kw to aid in supplying the correct vacuum pump needed for your CNC table. Sold separately.

### Dust Collection

Phantom CNC Systems offers several levels of dust collection to meet your needs. Our line-up of dust collectors include pleated filters. Sold separately.

## GET IN TOUCH

(252) 229-3896

info@phantomcn systems.com  
 www.phantomcn systems.com

276 Bailey Lane  
 Vanceboro, NC 28586

- 1 Bakelite Vacuum Table Surface
- 2 Pneumatic Rollers
- 3 Vacuum Multi-Zone Controls
- 4 Emergency Stop Button
- 5 Air Vacuum Pressure Gauge
- 6 T-Track Clamping System
- 7 Air-cooled 16.1HP 12KW Spindle
- 8 Rigid Tube Steel Gantry
- 9 Dust Boot
- 10 Fully Welded Steel Frame
- 11 Assist Roller

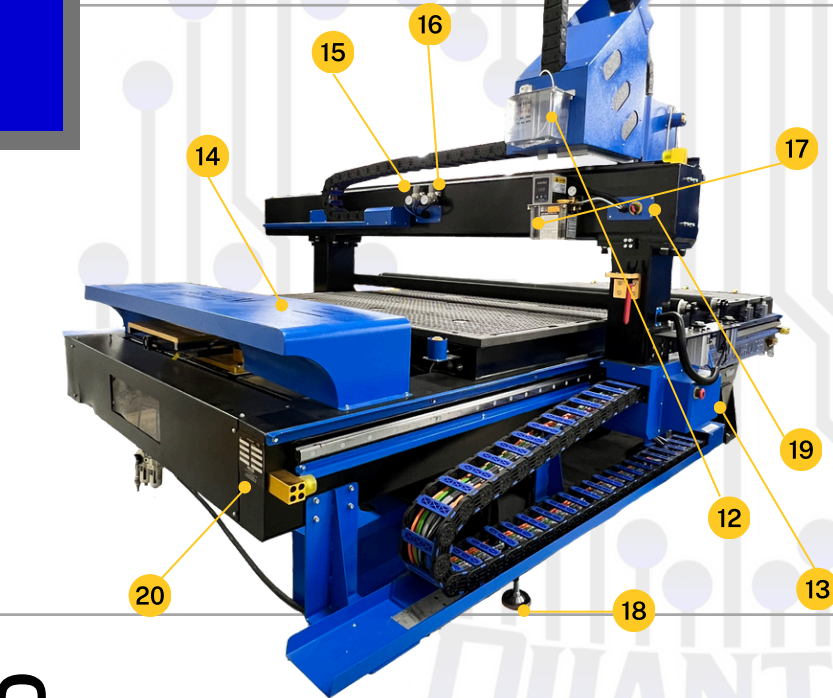
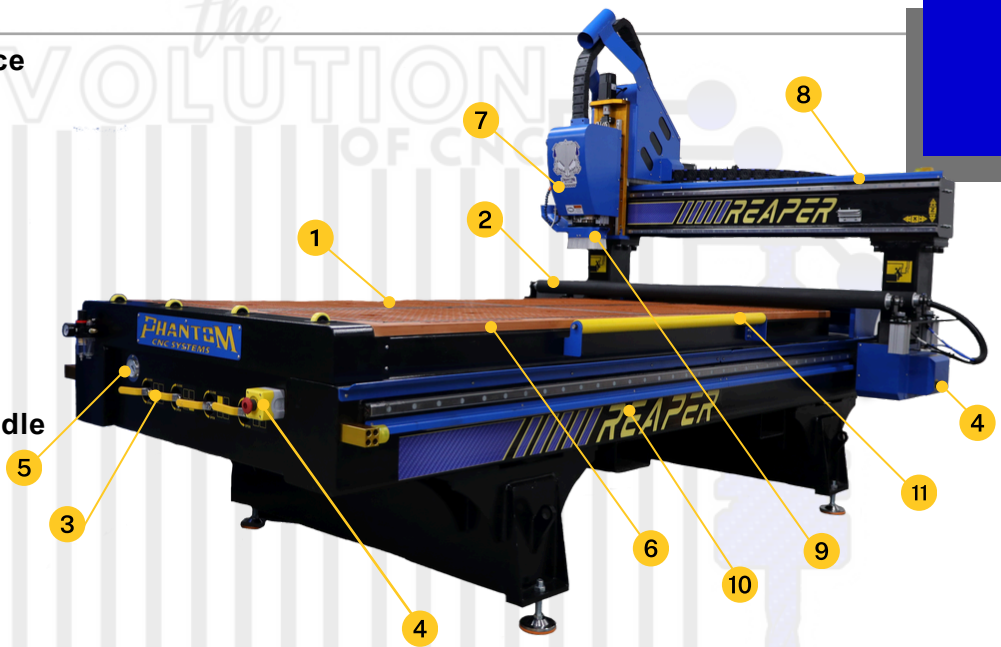

- Mist Cooling Lubrication Tank 12
- Emergency Stop Button 13
- 8 Position Tool Rack 14
- Oil-Mist Cooling System 15
- Z Axis Lubrication Tank 16
- XY Lubrication Tank 17
- Heavy Duty Leveling Casters 18
- Gantry Wiring Access Point 19
- Data Tag 20

**INCLUDED**

- 1 Welcome Package
- 1 Swag Bag
- 1 1/4" Collet
- 1 1/2" Collet
- 1 Collet Nut
- 1 Dust Hose
- 1 Dust Boot
- 1 Spanner Wrench
- 1 Tool Calibration Probe
- 1 Dust Rack
- 1 Vacuum Hose
- 4 Tool Holders



**CONTACT US**

276 Bailey Lane  
Vanceboro, NC 28586

(252) 229-3896  
www.phantomcncsystems.com